

**EVENT CENTER  
 DJ&J ENTERPRISES  
 LEAH DR, HILLSBOROUGH, NC  
 SITE PLAN**

**PARKING CALCULATION:**  
 REQUIRED: 1 PARKING SPACE PER 100 SQ FT GFA  
 $6486/100 = 64.86 = 65$  PARKING SPACES  
 PROVIDED: 65 PARKING SPACES INCLUDING 3 ACCESSIBLE PARKING SPACES

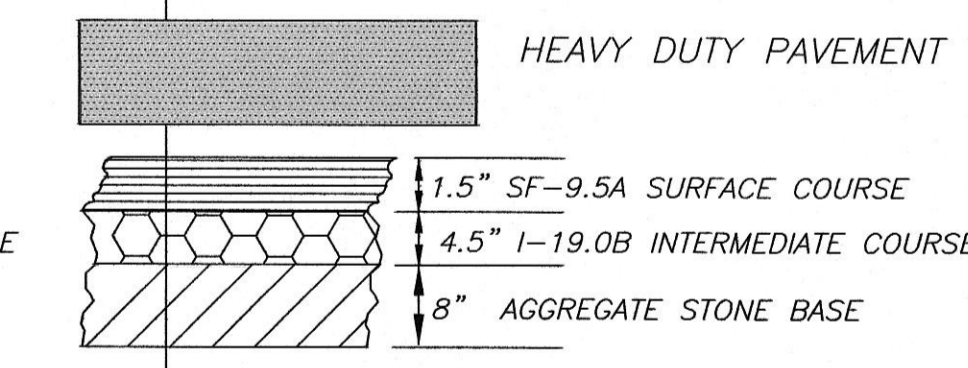
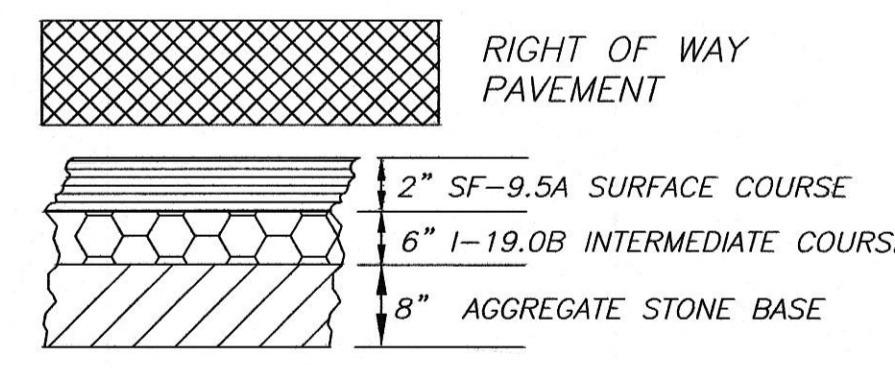
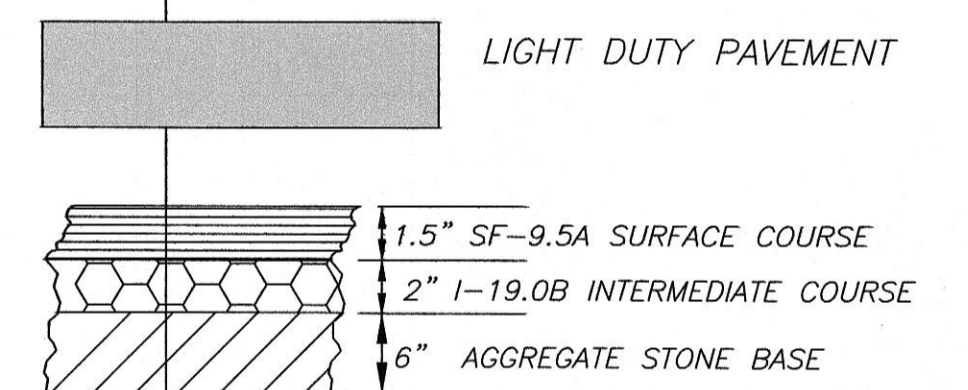
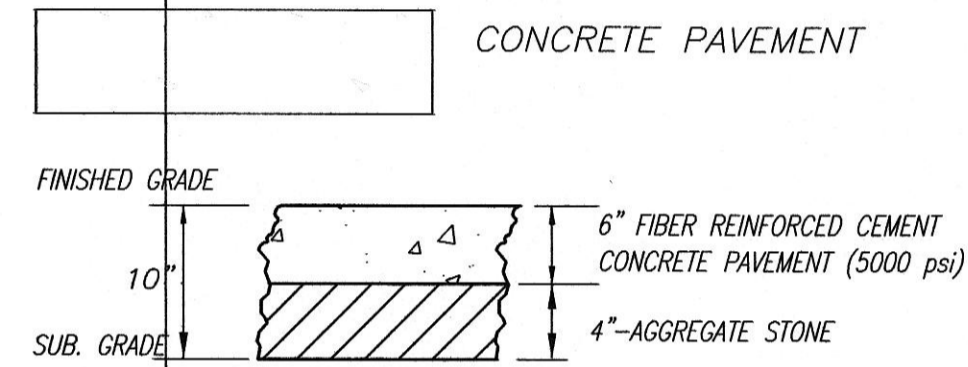
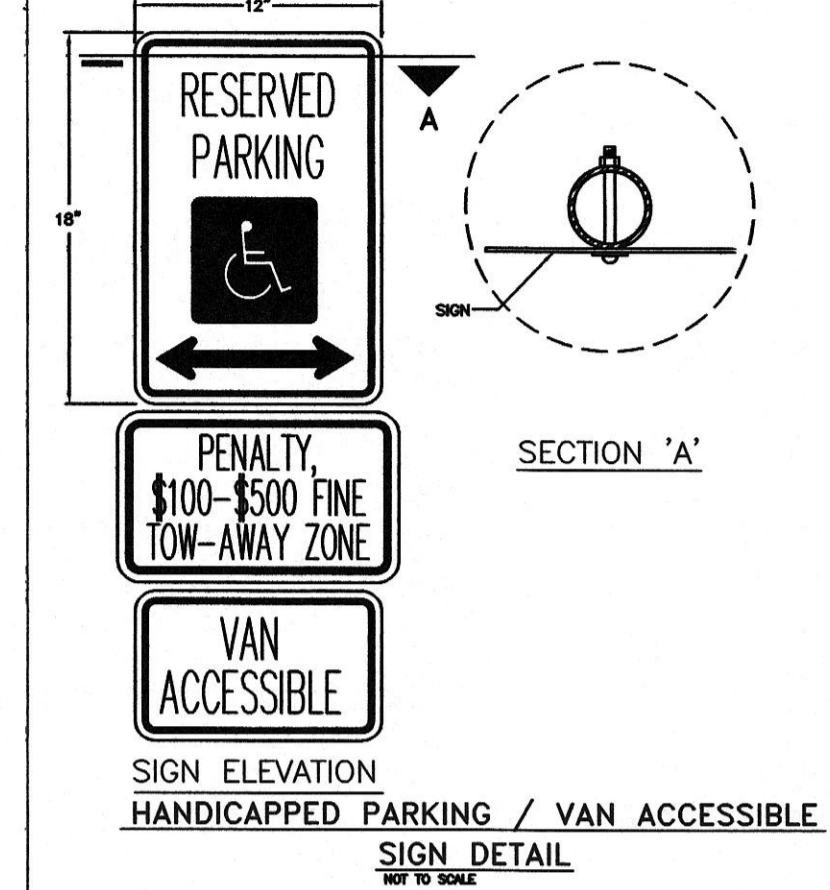
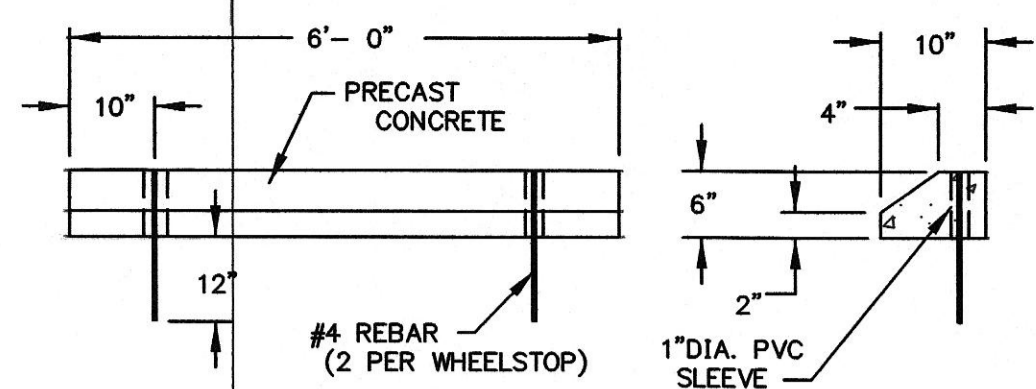

**CONCRETE SIDEWALK NOTES:**  
 1. CONCRETE SIDEWALKS SHALL BE 4" THICK OF 4000 PSI P/C CONCRETE OVER 6" COMPACTED AGGREGATE STONE BASE ON SUBGRADE COMPACTED TO 95% OF STANDARD PROCTOR DENSITY.

- LEGEND**
- ⊙ IRON PIN FOUND
  - PF IRON PIPE FOUND
  - RF IRON ROD FOUND
  - △ CONTROL POINT
  - ⊙ SANITARY SEWER MANHOLE
  - SS UNDERGROUND SANITARY SEWER
  - W WATER VALVE
  - ⊙ GAS VALVE
  - /// EDGE OF PAVEMENT
  - RCP REINFORCED CONCRETE PIPE
  - PVC POLYVINYL CHLORIDE PIPE
  - EDGE OF WOODS
  - ⊠ RIP RAP
  - CONCRETE

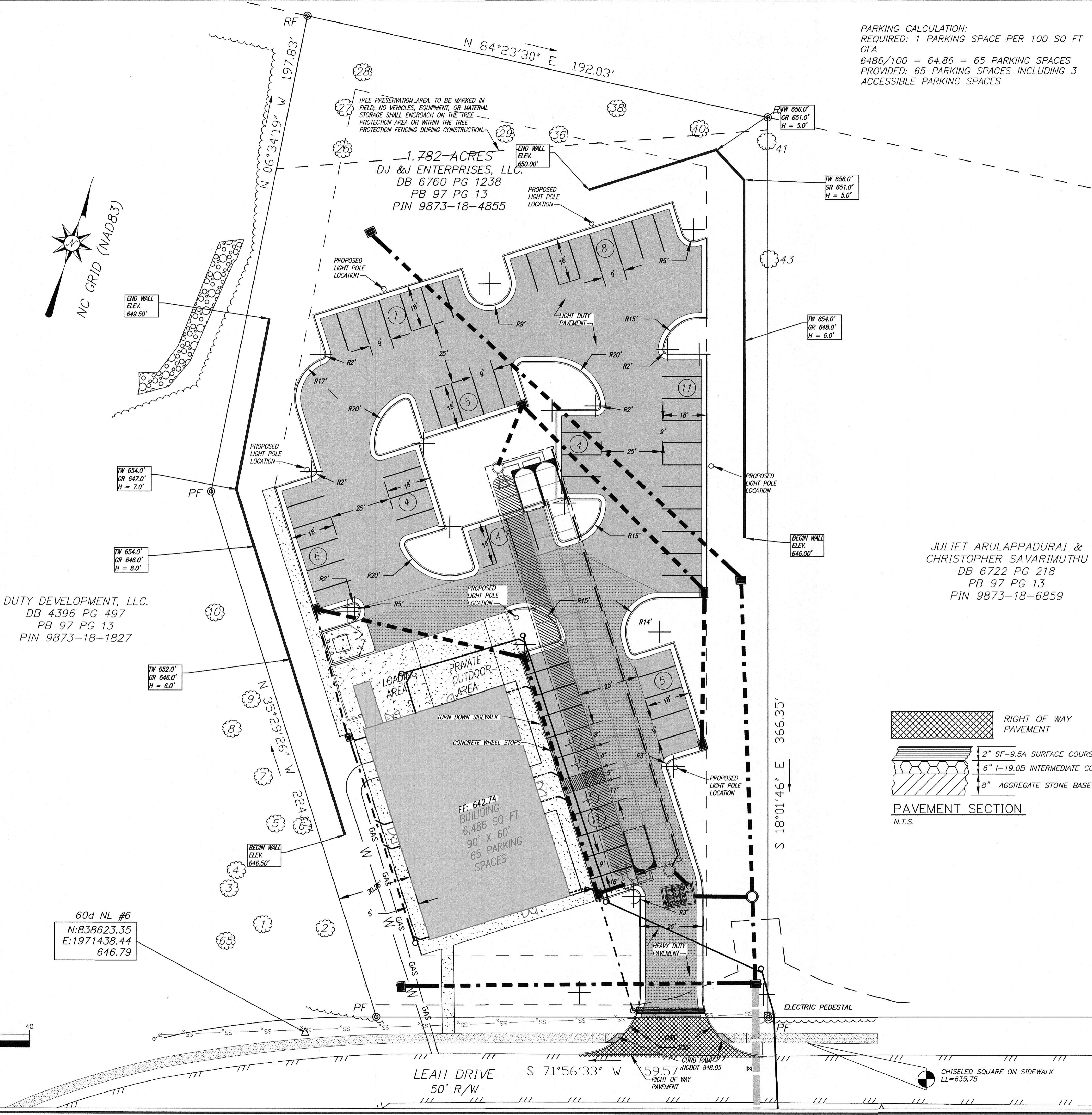

**DUTY DEVELOPMENT, LLC.**  
 DB 4396 PG 497  
 PB 97 PG 13  
 PIN 9873-18-1827

**JULIET ARULAPPADURAI &  
 CHRISTOPHER SAVARIMUTHU**  
 DB 6722 PG 218  
 PB 97 PG 13  
 PIN 9873-18-6859

60d NL #6  
 N:838623.35  
 E:1971438.44  
 646.79

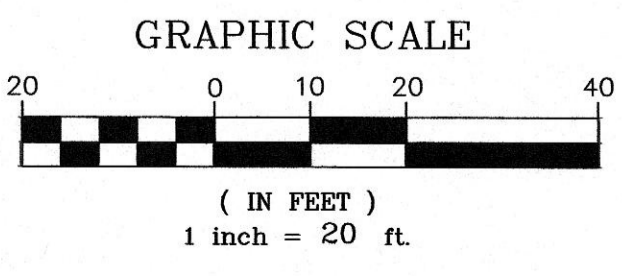

NO.	DATE	DESCRIPTION	BY